

Explosion-proof roof fans

WPW -03÷05/D/Ex



 II 2 G T3

Application

Fans are designed for use in areas of explosion risk. The fans are for ventilation of buildings of larger cubature and are installed on roof bases.

Structure

The fan is constructed of two discs spaced by pins. All these parts together with a net circumference surface are forming a cylindrical corpus. In the lower disc is an inlet with grill and flange, whereas on the upper disc is fastened an explosion-proof flange motor. The radial brass impeller is mounted on the motor pivot and is working in a space between the discs*. The motor and the impeller are protected from atmospheric factors by a conic steel hood. On the fan housing is a clamp with a copper cable to lead the electrostatic loads away. The fans are manufactured with motors of synchronous rotations 1500 r.p.m. (The sizes 04, 05 are also with motors of 1000 r.p.m.).

WPW-03/D/Ex/1500

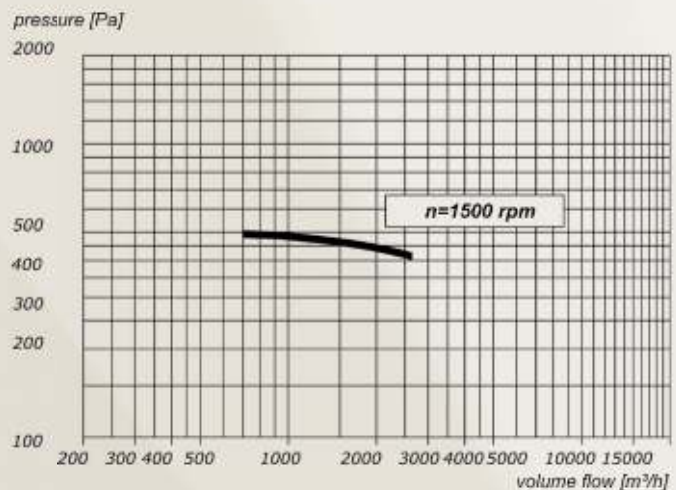
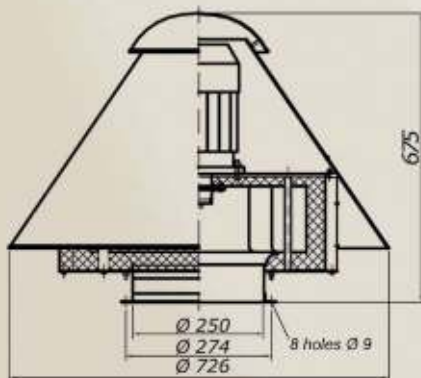

WPW-04/D/Ex/1500
WPW-04/D/Ex/1000

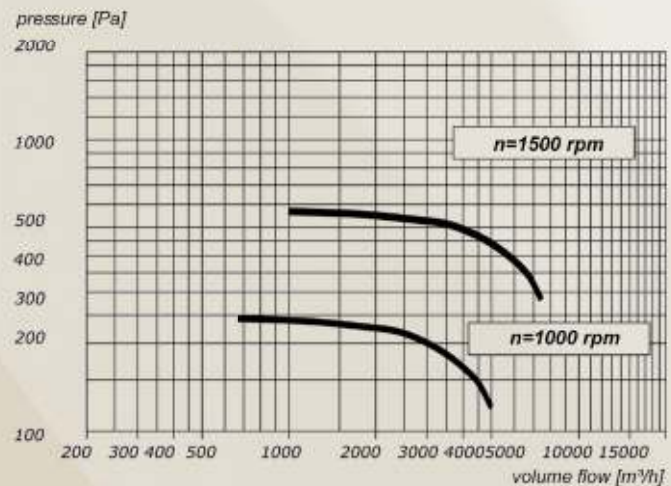
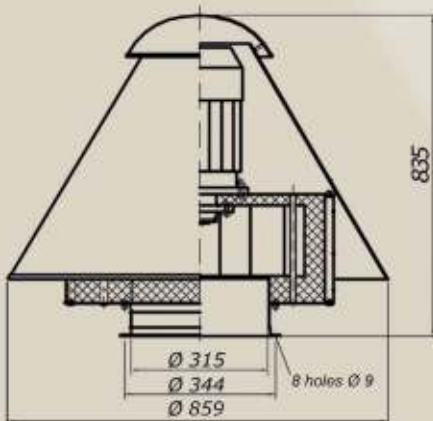

* The type WPW-05/D/Ex has an impeller made of stainless steel.

WPW-05/D/Ex/1000
WPW-05/D/Ex/1500

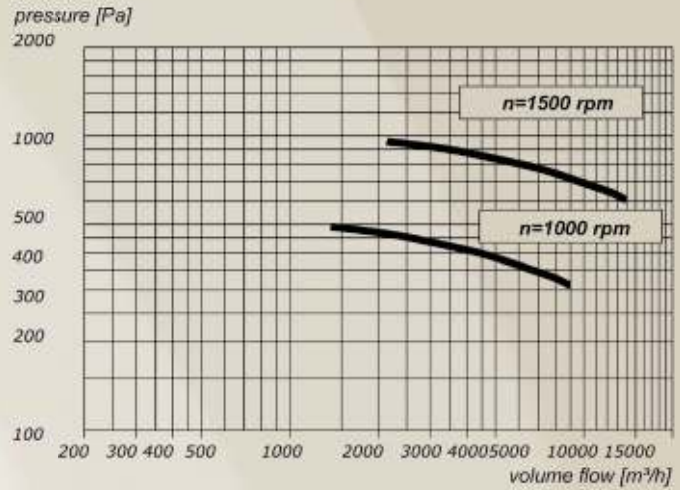
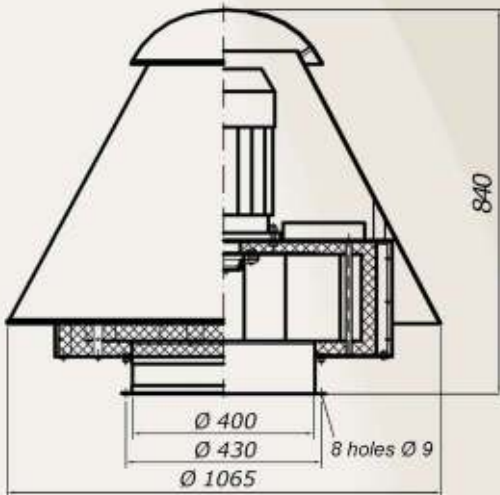

Technical data

Type	Type of the motor	Part №	Supply voltage [V]	Synchronous rotations [1/min]	Motor rate [kW]	Rated current [A]	Noise level [dB(A)] from distance		IP	Weight [kg]
							1 m	5 m		
WPW 03/D/Ex/1500 II 2 GT3	Indukta EExe II Sh-90S-4-T4 wg	808W30	3 × 400	1500	0,8	2,0	75	62	55	48
WPW 04/D/Ex/1500 II 2 GT3	Indukta EExe II Sh-90L-4-T3 wg	808W31	3 × 400	1500	1,5	3,7	78	68	55	65,5
WPW 04/D/Ex/1000 II 2 GT3	Indukta EExe II Sh-90S-6-T3 wg	808W32	3 × 400	1000	0,75	2,1	65	55	55	62
WPW 05/D/Ex/1500 II 2 GT3	Indukta EExe II Sh-100L-4B-T3 wg	808W33	3 × 400	1500	3,0	6,9	82	76	55	113
WPW 05/D/Ex/1000 II 2 GT3	Indukta EExe II Sh-90L-6-T3 wg	808W34	3 × 400	1000	1,1	3,0	73	65	55	94

1. Maximum temperature of the forwarded air +60°C. Maximum temperature in the work area +40°C.
2. The fans can be applied for conveying the dry air of maximum dustiness 0,3 g/m³.
3. The fans cannot be used for forwarding the air containing viscous impurities that could deposit on the device, especially on the impeller, and containing aggressive compounds which would have destructive effect on the device.

Accessories



Roof base BI



Roof base BII